

Mechanical Clamps VCMC-S4-QUICK

For TVN systems from SCM · Clamping range up to 85 mm · With quick adjustment

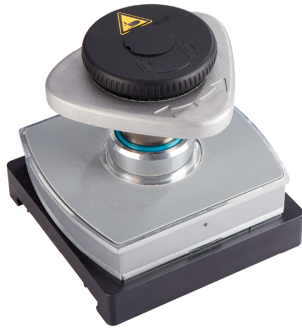

Mechanical Clamps VCMC-S4-QUICK

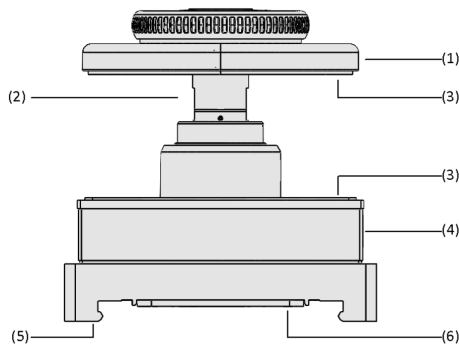

System design Mechanical Clamps VCMC-S4-QUICK



Mechanical clamps VCMC-S4-QUICK for clamping of frame parts

Suitability for industry specific applications

Application

- Mechanical clamping system for CNC machining centers from SCM / Morbidelli with TVN console tables
- Particularly suitable for narrow and curved workpieces such as frame parts and window profiles
- Set-up is efficient, safe and tool-free; the clamp is mechanically pre-fixed
- Tool-free adjustment of the clamping height to the workpiece within seconds; extension of the clamping range possible through extension
- Clamping of the workpiece by activating the vacuum on the machine table

Design

- Triangular clamping disc (1) is adjustable in clamping height and contact surface on the workpiece without tools and is lowered by activating the vacuum
- Extension (2) for adjusting the clamping range
- Friction material (3) for optimizing lateral force absorption
- Robust main body (4) made of aluminum with dovetail mount (5) for fixing on TVN consoles from SCM / Morbidelli
- Durable sealing frame (6) optimized for effortless sliding of the clamp on the console

Product highlights

- Triangular clamping disc with tool-free quick adjustment enables shortest set-up times
- Holds even narrow workpieces securely with clamping forces of up to 700 N
- No additional medium required, as the clamp can be activated via operating vacuum of the CNC machining centre
- Special friction materials on the clamping disc and clamping surface ensure a secure hold even with high machining forces

Mechanical Clamps VCMC-S4-QUICK

For TVN systems from SCM · Clamping range up to 85 mm · With quick adjustment

Designation code Mechanical Clamps VCMC-S4-QUICK

VCMC-S4	–	QUICK	–	145x145	–	x50	–	15-85
1		2		3		4		5

1 – Abbreviated designation

Code	Type
VCMC-S4	Mechanical clamp, SCM/Morbidelli TVN system

2 – Design

Code	Type
QUICK	With tool-free height adjustment

3 – Dimensions

Code	LxW in mm
145x145	145x145

4 – Clamping height

Code	H in mm
x50	50

5 – Clamping range

Code	Clamping range in mm
15-85	15-85

The mechanical clamp VCMC-S4-QUICK is delivered completely assembled. The product consists of:

- Clamping disc with quick adjustment
- Main body made of aluminum
- Mounting for TVN console

Available spare parts: clamping disc, sealing frame

Available accessories: clamping range extension

Ordering data Mechanical Clamps VCMC-S4-QUICK

Type	Part no.
VCMC-S4-QUICK 145x145x50 15-85	10.01.12.04760

Ordering data Spare parts Mechanical Clamps VCMC-S4-QUICK

Spare parts	Part no.
Clamping disc	SPAN-TELL 128x30 EXZ VCMC 10.01.12.04740
Sealing frame (bottom)	VCDR 141x77.2x5.1 VCBL-S 10.01.12.03138

Ordering data Accessories Mechanical Clamps VCMC-S4-QUICK

Accessories	Part no.
Extension with hexagon	VRL-S M20x1x35 10.01.12.04374

Technical data Mechanical Clamps VCMC-S4-QUICK

Type	Clamping range [mm]
VCMC-S4-QUICK 145x145x50 15-85	15.0 ... 85.0 mm

Mechanical Clamps VCMC-S4-QUICK

For TVN systems from SCM · Clamping range up to 85 mm · With quick adjustment

Design data Mechanical Clamps VCMC-S4-QUICK

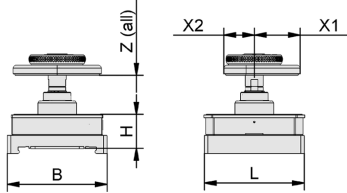

VCMC-S4-QUICK

Mechanical Clamps VCMC-S4-QUICK

For TVN systems from SCM · Clamping range up to 85 mm · With quick adjustment

Design data Mechanical Clamps VCMC-S4-QUICK

Type	B [mm]	H [mm]	L [mm]	X1 [mm]	X2 [mm]
VCMC-S4-QUICK 145x145x50 15-85	145	50	145	66.5	44